

Version:
December 01, 2022.

DEMINT

Electronics Co., Ltd.

(LT 455/450 U/W)

Communication Ceramic Filters

Web: www.direct-token.com

Email: rfq@direct-token.com

DeMint Electronics Co., Ltd.

China: 17P, Nanyuan Maple Leaf Bldg., Nanshan Ave.,
Nanshan Dist., Shenzhen, Guangdong, China. 518054
Tel: +86 755 26055363

Taiwan: No.137, Sec. 1, Zhongxing Rd., Wugu District,
New Taipei City, Taiwan. 248012
Tel: +886 2981 0109 Fax: +886 2988 7487

▶ Product Introduction

Introduction (LT 455/450 U/W)

Features :

- LT455 EU Dimensions: (7.0 × 8.0 × 8.0 mm).
- LT455 EW Dimensions: (7.0 × 11.0 × 8.0 mm).
- Center frequency: 450KHz, 455KHz.
- Pass Band Ripple (dB) Max.: 2 db.
- Insertion Loss (dB) Max.: 4 db, 6 db.
- Input / Output Impedance: 1000Ω ~ 2000Ω.

DeMint Ceramic Filters Address the G.D.T. Characteristics for Communication (Murata CF, SF Compatible). DeMint ceramic filters for communication LT 455/450 U/W series are 4-element and 6-element devices connected in ladder form. These highly selective filters are designed to address the G.D.T. characteristics required in digital communications.

The excellent G.D.T. characteristics allow these filters to be utilized in areas such as the mobile cellular markets as well as a variety of stereo applications. (Also available in 450 KHz version.)

Custom parts are available on request. DeMint will also produce devices outside these specifications to meet specific customer requirements, please contact our sales or link to DeMint official website "[Ceramic Filters](#)" for more information.



► **Dimensions**

Dimensions (Unit: mm) (LT 455/450 U/W)

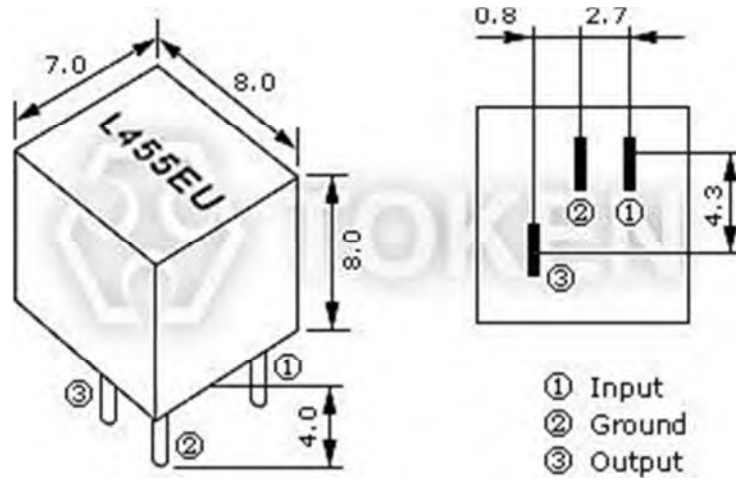

(LT 455 EU) Dimensions

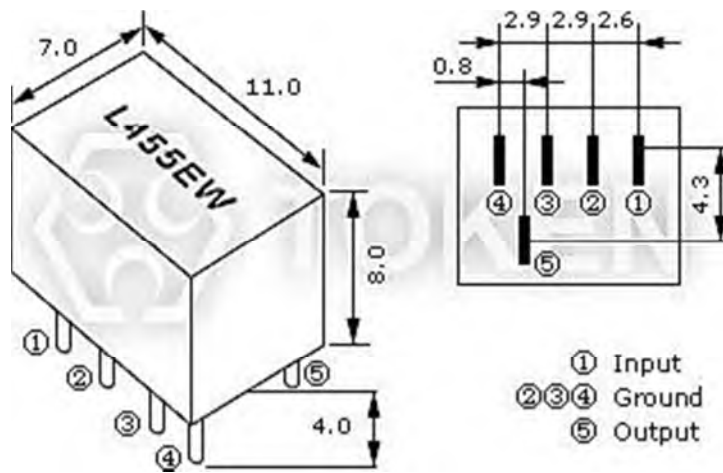

(LT 455 EW) Dimensions

▶ Technical Characteristics

Technical Characteristics (LT 455/450 U/W)

| Part Number | | Center Frequency (KHz) | Insertion Loss (dB) Max. | Pass Band Ripple (dB) Max. | 6dB Band Width (KHz) Min. | 40dB Band Width (KHz) Max. (LT455 U) | 50dB Band Width (KHz) Max. (LT455 W) | Spurious Attenuation fo±100KHz (dB) Min. | | Input / Output Impedance (Ω) |
|-------------|----------|------------------------|--------------------------|----------------------------|---------------------------|--------------------------------------|--------------------------------------|--|-----------|------------------------------|
| | | | | | | | | (LT455 U) | (LT455 W) | |
| LT455AU | LT455AW | 455±2.0 | 4 | 2 | ±17.5 | ±40 | ±35 | 28 | 40 | 1000 |
| LT455BU | LT455BW | 455±2.0 | 4 | 2 | ±15 | ±30 | ±30 | 28 | 40 | 1500 |
| LT455CU | LT455CW | 455±2.0 | 4 | 2 | ±12.5 | ±24 | ±24 | 28 | 40 | 1500 |
| LT455DU | LT455DW | 455±1.5 | 4 | 2 | ±10 | ±20 | ±20 | 28 | 40 | 1500 |
| LT455EU | LT455EW | 455±1.5 | 6 | 2 | ±7.5 | ±15 | ±15 | 28 | 40 | 1500 |
| LT455FU | LT455FW | 455±1.5 | 6 | 2 | ±6 | ±12.5 | ±12.5 | 28 | 40 | 2000 |
| LT455GU | LT455GW | 455±1.5 | 6 | 2 | ±4.5 | ±10 | ±10 | 28 | 40 | 2000 |
| LT455HU | LT455HW | 455±1.0 | 6 | 2 | ±3 | ±9 | ±9 | 28 | 40 | 2000 |
| LT455IU | LT455IW | 455±1.0 | 6 | 2 | ±2 | ±7.5 | ±7.5 | 28 | 40 | 2000 |
| LT455HTU | LT455HTW | 455±1.0 | 6 | 2 | ±3 | ±9 | ±9 | 35 | 60 | 2000 |

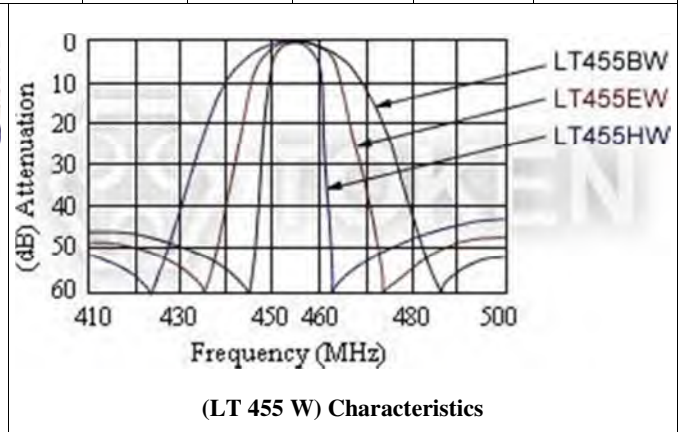
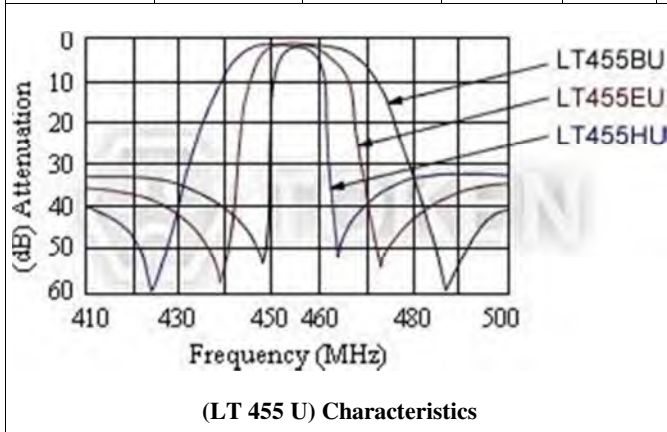

● Center frequency 450KHz is also available.



▶ **Test Circuit**

Test Circuit (LT 455/450 U/W)

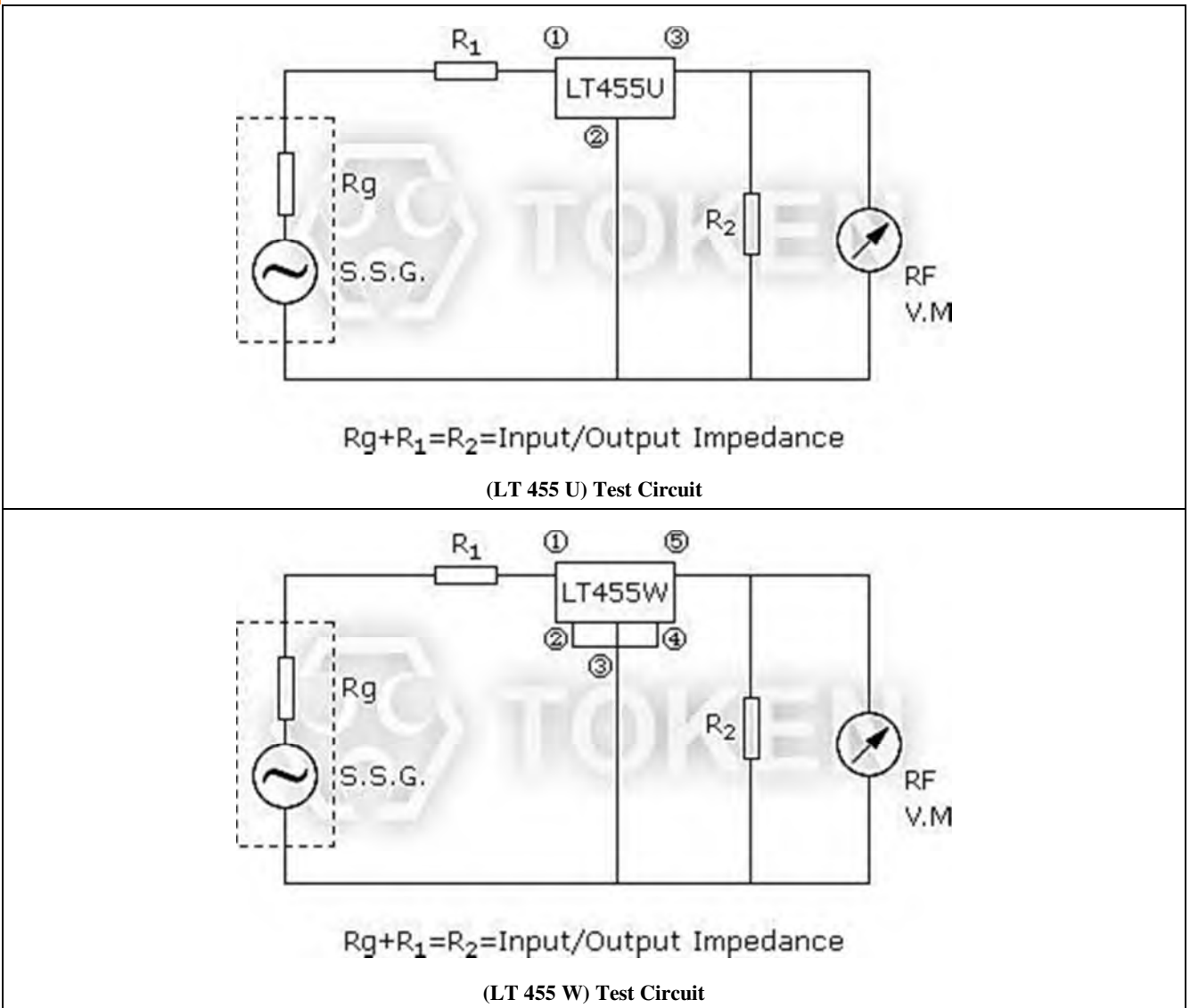

▶ **Order Codes**

Order Codes (LT 455/450 U/W)

| | |
|-------------|---------|
| LT455BU | P |
| Part Number | Package |

► General Information

Introduction of Filters

For more than two decades, piezo technology has been instrumental in the proliferation of solid state electronics. A view of the future reveals that even greater expectations will be placed on piezoelectric material in the area of new applications and for more stringent performance criteria in modern products.

DeMint sophisticated ceramics technology has greatly increased selectivity and wide-band characteristics, and has stabilized the characteristics of ceramic filters. The series covers a wide range of attenuation and bandwidths to allow selection of the most optimum filter characteristics for each application.

DeMint filters are band pass filters consisting of one or more ceramic resonators connected in a ladder network configuration. Pass band characteristics are determined by the relative resonant and anti-resonant frequencies of the resonators. Both narrow and wide pass band configurations are manufactured by adjusting the resonator frequency characteristics.

The IC (Integrated Circuit) has found wide use in the field of commercial equipment, such as automotive radios, stereo systems, 2-way communications, TV sets, etc. Thus, new miniature integrated filters, with high performance, are extremely desirable for use in IF circuits.

Furthermore, radio wave disturbance due to rapid progress of data transmitting rate and remarkable sophistication of communication network have become significant traffic conflicts. Accordingly, the demand for filters with high selectivity and wide pass band width has boosted.

The IC application of the active elements will continue its progress, and there will be a growing demand for highly selective, non-adjustable, miniature and wide pass band width IF circuit.

Advantage of DeMint Piezoelectric Filters

DeMint Electronics had been able to develop specialized piezo materials which when combined with an advance design have resulted in a complete line of practical, inexpensive piezo devices for entertainment and communications applications.

DeMint reliably deliver high-quality components according to the each customer special needs with respect to performance, costs, and technology modifications.

For marketing discontinuations or sourcing activities concerning Piezoelectric Filter products, you are encouraged to contact our Sales Department so the request can be properly directed within DeMint.

