

Version:
December 01, 2022

DEMINT

Electronics Co., Ltd.

(DRB16) Long Lead Wirewound Enameled Resistors

Web: www.direct-token.com

Email: rfq@direct-token.com

DeMint Electronics Co., Ltd.

China: 17P, Nanyuan Maple Leaf Bldg., Nanshan Ave.,
Nanshan Dist., Shenzhen, Guangdong, China. 518054
Tel: +86 755 26055363

Taiwan: No.137, Sec. 1, Zhongxing Rd., Wugu District,
New Taipei City, Taiwan. 248012
Tel: +886 2981 0109 Fax: +886 2988 7487

▶ Product Introduction

DeMint (DRB16) provides vertical lead and horizontal lead for easy installation, small size, and high resistance.

Features :

- Small size, high resistance.
- Simple structure, easy to install.
- Vertical lead and horizontal lead two kinds of installation methods.

Applications :

- Welding machine, power supply.
- Electric tools, high voltage applications.
- Consumer product application, switch application.

DeMint Electronics provides (DRB16) Long Lead Wirewound Enameled Resistor. Long leads give two types of installation in vertical and horizontal leads with competitive prices. Resistance range from 1Ω to 10KΩ, power range from 3W ~ 20W, and the highest operating voltage from 120V to 750V are available. Size and specification match the industry standard.

The vertical and horizontal lead type glass glaze resistor is the resistance wiring around the heat-resistant porcelain body. Surface coated with wet-resistant, heat-resistant, non-corrosive coatings (such as silicone, epoxy resin, cement, glaze porcelain, etc.) for protection. Its characteristics are: small temperature coefficient, excellent heat resistance, light weight, low noise, overload resistance, low resistance change rate, and better heat transfer characteristics than conventional wire-wound power resistors. Lead-free product (DRB16) meets RoHS Standard and lead-free standard.

The vitreous enamelled resistor (DRB16) is used to replace the traditional paint of the resistance body, and the resistance caused by the unbearable thermal stress "high temperature". (DRB16) provides durable lead-free enameled coatings that allow wirewound resistors to maintain a hardened coating that can be worked in high temperature environments. The fully welded structure strengthens the mechanical integrity.

When cost, quality, and reliability are key factors, the power type (DRB16) line winding is the best choice. It can provide Ayrton Perry line-winding application requirements. These (DRB16) come with short production cycle, and widely used in power tools, switch applications, power supplies, welding machines, high voltage applications, consumer product applications, home entertainment, home appliances products. For the customized special applications, please contact our sales to discuss the details. Or link to DeMint official website "[General Purpose Resistors](#)" for more information.



► Technical Specifications

Enameled Wirewound Resistor Long Leads (DRB16) - Specifications (Unit: mm)

Type	Rating Power (W)	Resistance (Ω)	Resistance Tolerance (%)	Temperature Coefficient (ppm/°C)	Working Voltage (V)	Dimensions (mm)					
						L ±1	OD ±1	ID ±1	e ±3	d ±0.2	H ±1
DRB16-3	3W	1 ~ -1k	±5% (J)	250	120	11	7.5	3.6	38±3	0.8	7
DRB16-5	5W	5 ~ -1.5k			150	16	8.5	3.6	38±3	0.8	11
DRB16-6	6W	6 ~ -4.7k	±10% (K)	250	250	25	10.5	4.8	38±3	1	19
DRB16-12	12W	12 ~ -4.7k			600	44.5	10.5	4.8	38±3	1	36.5
DRB16-20	20W	20 ~ -10k			750	51	14.3	7.9	38±3	1	43

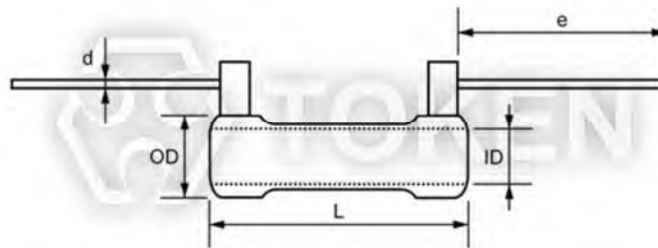

Horizontal Long Lead Enameled Wirewound Resistor (DRB16)

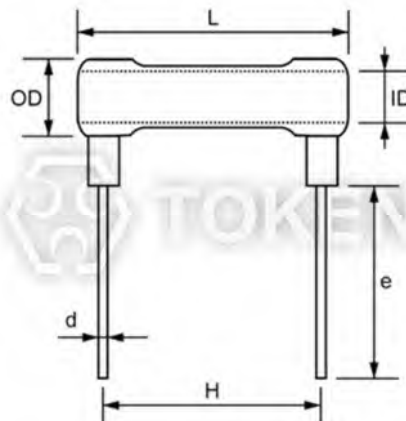

Vertical Long Lead Enameled Wirewound Resistor (DRB16)

► Electrical Performance

Vitreous Enamelled Resistor (DRB16) Performance

Test Item	Characteristics	Test Methods
Solderability	Free flow of solder	235°C ± 5°C, 2s Groove welding
Terminal strength	$\Delta R \leq \pm (1\%R + 0.05\Omega)$	$\leq 4.3W$ 10N, $\geq 6W$ 20N
Overloading	$\Delta R \leq \pm (1\%R + 0.05\Omega)$	Applied 10 times the rated power load 5s
Rapid temperature Change	$\Delta R \leq \pm (1\%R + 0.05\Omega)$	$\theta A = -55^\circ C$ $\theta B = +200^\circ C$, 5 Cycles
Collision Test	$\Delta R \leq \pm (1\%R + 0.05\Omega)$	Acceleration 390m/s ² , 4000 times
Impact Test	$\Delta R \leq \pm (1\%R + 0.05\Omega)$	Acceleration 490m/s ² , 11ms, 18 times
Vibration Test	$\Delta R \leq \pm (2\%R + 0.1\Omega)$	Frequency 10-500Hz, Acceleration 98m/s ² , 6h
Temperature Rise	<245°C	Apply rated power Load
Constant Damp Heat	$\Delta R \leq \pm (5\%R + 0.1\Omega)$	Temperature 40±2°C, Temperature 93+2/-3%, 56h
Room temperature Durability	$\Delta R \leq \pm (5\%R + 0.1\Omega)$	Rated power load at room temperature 1000h

► Derating Curve

Derating Curve (DRB16)

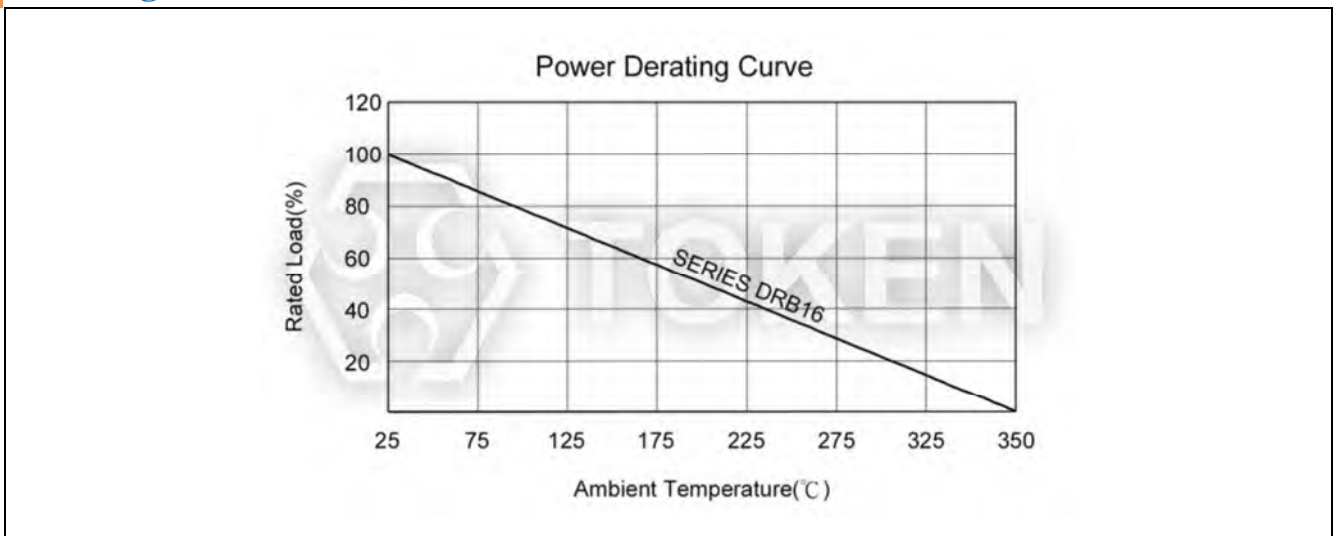

► Order Codes

Long Lead Enameled Wirewound Resistor - (DRB16) Order Codes

DRB16	-	3		10R		J		VL		VE	
Type		Rating Power (W)		Resistance Value (Ω)		Resistance Tolerance		Lead Type		Coating	
DRB16		3	3W	10R	10 Ω	G	$\pm 2\%$	VL	Vertical Lead	VE	Vitreous Enamelled
		5	5W	110R	110 Ω	J	$\pm 5\%$	HL	Horizontal Lead	LF	RoHS Enamelled
		6	6W	1K1	1.1K Ω					NF	Nonflammable Epoxy
		12	12W	10K	10K Ω						
		20	20W								



► General Information

General Purpose Resistors with Customized Service

DeMint Electronics is expanding business to include a broad range of General Purpose Resistor products designed for high volume applications. This expanded range of commercial resistor presents a more comprehensive product offering for Customer Experience Management (CEM) and other high volume customers that require quality products at competitive pricing.

Backed by the same customer service, technical support and quality assurance that DeMint has always provided, these new commercial products enable you the opportunity to source a wider range of resistors from a trusted supplier.

General Use

When an ambient temperature exceeds a rated ambient temperature, resistor shall be applied on the derating curve by derating the load power. General purpose resistor under overloads is not combustion resistant and is likely to emit, flame, gas, smoke, red heat, etc. Flame retardant resistor generally emits smoke and red heat in a certain power and over but do not emit fire or flame.

When resistors are shielded or coated with resin etc., stress from the storage heat and the resins are applied. So, performance and reliability should be checked well before use.

When a voltage higher than rated is applied in a short time (single pulse, repeated pulses, surge, etc.), it does not necessarily ensure safety that an effective wattage is not higher than a rated wattage. Then consult with us with your specified pulse wave shape. Resistors shall be used in a condition causing no dew condensation.

Keep temperature from rising by choosing resistor with a higher rated capacity; do not use a component having the exact load value required. For considerations of safety in extended period applications, the rating should be more than four times higher than the actual wattage involved, but never use resistors at less than 25% of its rated power.

In applications where resistors are subject to intermittent current surges and spikes, be sure in advance that the components selected are capable of withstanding brief durations of increased load.

Do not exceed the recommended rated load. Resistor must use within the rated voltage range to prevent the shortening of service life and/or failure of the wound resistance elements.

Minimum load: Resistor must be utilized at 1/10 or more of the rated voltage to prevent poor conductance due to oxidation build-up. For basic particulars for cautions, refer to EIAJ Technical Report RCR-2121 "Guidance for care note on fixed-resistors".

